



**PREVOST.**  
THE ULTIMATE EXPERIENCE

# PrevoSt Motorhome Expo

West Palm PrevoSt-Stuff

Robert Hitt

# Agenda



- Get to know your VIN
  - Scheduled maintenance
  - Prevost Service Network
  - Customer Support
  - Prevost APPS
  - Prevost Uptime

# Service Maintenance Resources



# VEHICLE IDENTIFICATION NUMBER ( SHORT VIN)

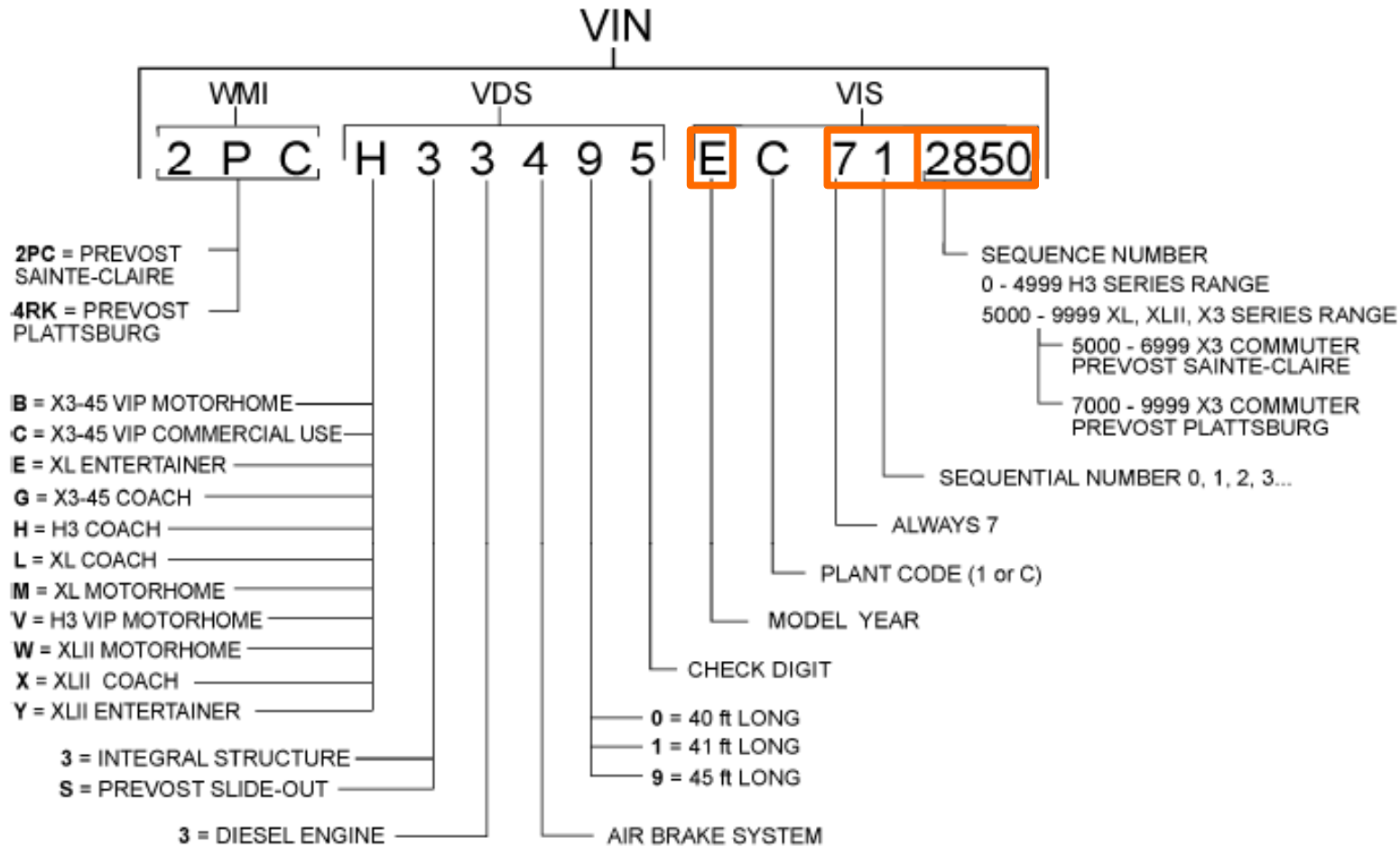

- **PrevoSt & PASS**
- Use for Tech Pubs & Parts Assist
- E-2850

- **Volvo**
- Use for IMPACT (Engine Parts)
- Chassis Series: PREVH
- Chassis ID: 712850

- **Chassis Series**
- PREVH – H3 Coaches
- PREVX – X3 Coaches



# VOLVO D13 EPA 10 FORWARD

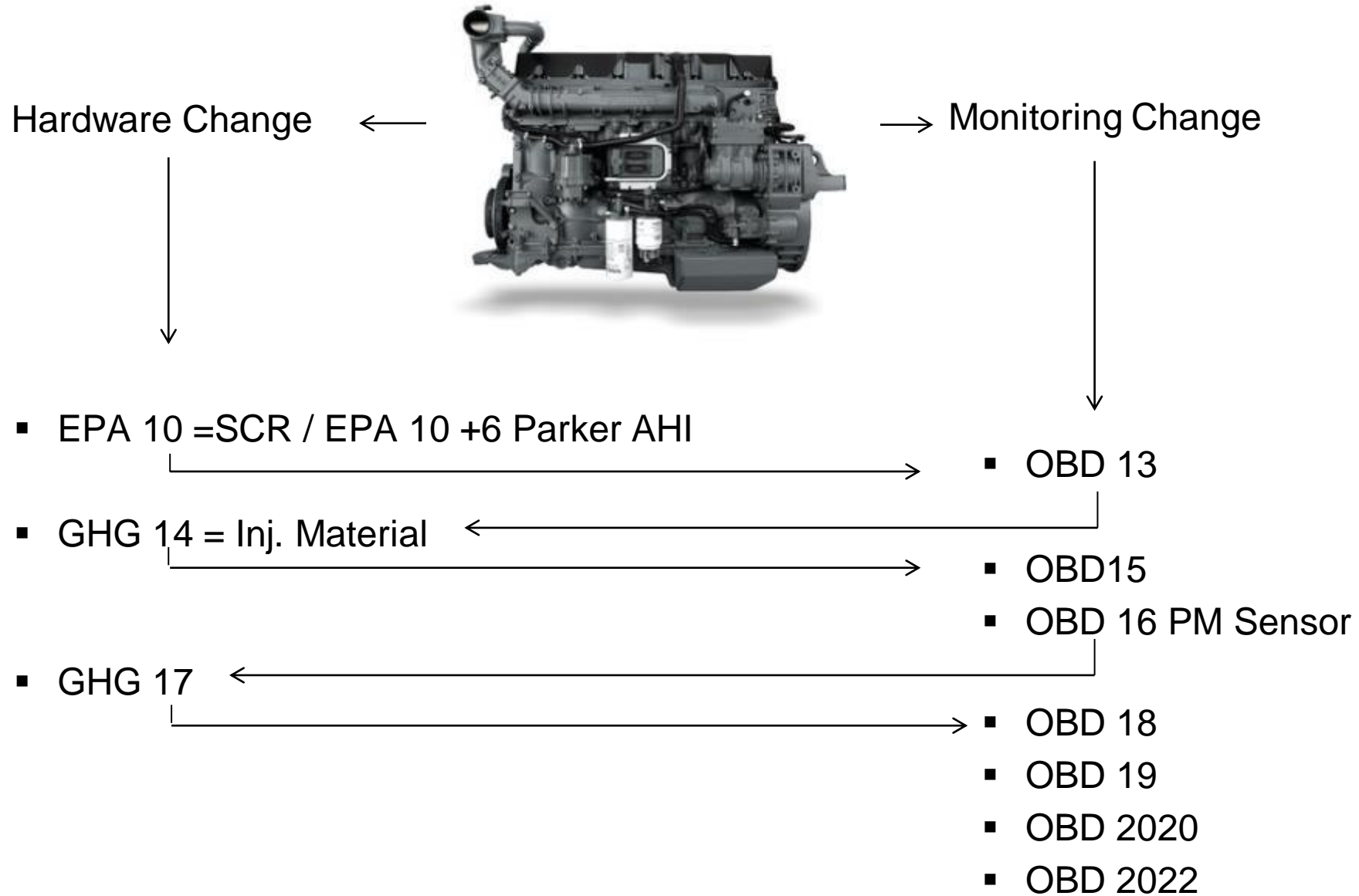

# MTH Service & Maintenance

## 5 LUBRICATION AND SERVICING SCHEDULE - MOTORHOMES

LUBRICATION AND SERVICING SCHEDULE			ITEM	EVERY (months)	LUBRICANT / FLUID <sup>®</sup>
H3-45 VIP & X3-45 VIP MOTORHOMES (Private Use)					
A red stripe in the left margin of the schedule highlights the latest changes					
<b>GENERAL</b>					
All flexible hoses – inspect				12	
H3 VIP Series only: Main power compartment fan air filter – inspect				12	
<b>01 ENGINE</b>					
Engine oil and filters – change			24	12	<a href="#">A</a> <a href="#">B</a> <a href="#">C</a>
Air cleaner – change filter element			30	24	
Engine mounted alternators & house alternator(s) – change drive belts and intermediary drive belts				24	
Drive belts (all) – check tension, inspect for cracks or frayed material, change belt that display obvious wear or defects				12	
Drive belts (all) – change				24	
Valves and injectors – initial adjustment: after 2 500 hours or 36 months whichever occurs first			24	36	
Valves and injectors – check and adjust: every 5 000 hours or 72 months whichever occurs first			24	72	
<b>03 FUEL</b>					
Primary fuel filter & secondary fuel filter – change at every engine oil change			21, 22		
<b>04 EXHAUST AND AFTERTREATMENT SYSTEM</b>					
DPF filter – either clean or change filter cartridge after 4 500 hours			33		
Aftertreatment Hydrocarbon Injector (AHI) nozzle – change after 4 500 hours					
DEF tank – drain and clean with water, clean filler neck strainer			32	12	
Diffuser assembly, rain cap & drain tube – check proper functioning, clean			34	24	
DEF pump – change filter element			32	36	

We have maintenance recommendations based on months rather than millage for customers that stay under the millage recommendations for these services.

Ask your service advisor for details on this as well as our UPTIME service agreements that lock in maintenance costs



**Service Network**





At Prevest, we share your passion for excellence. Our relentless pursuit of perfection continues long after a new coach heads off for a lifetime of service.

- ❑ 16 Prevest Service Centers
- ❑ More than 175 Prevest-trained and certified service providers
- ❑ Team of regional Customer Support Managers for urgent response
- ❑ The largest service network of any manufacturer in the industry
- ❑ Technical trainers to help keep your staff up to date



Converter Locations  Prevost Service Centers  Service Providers

**FILTER**

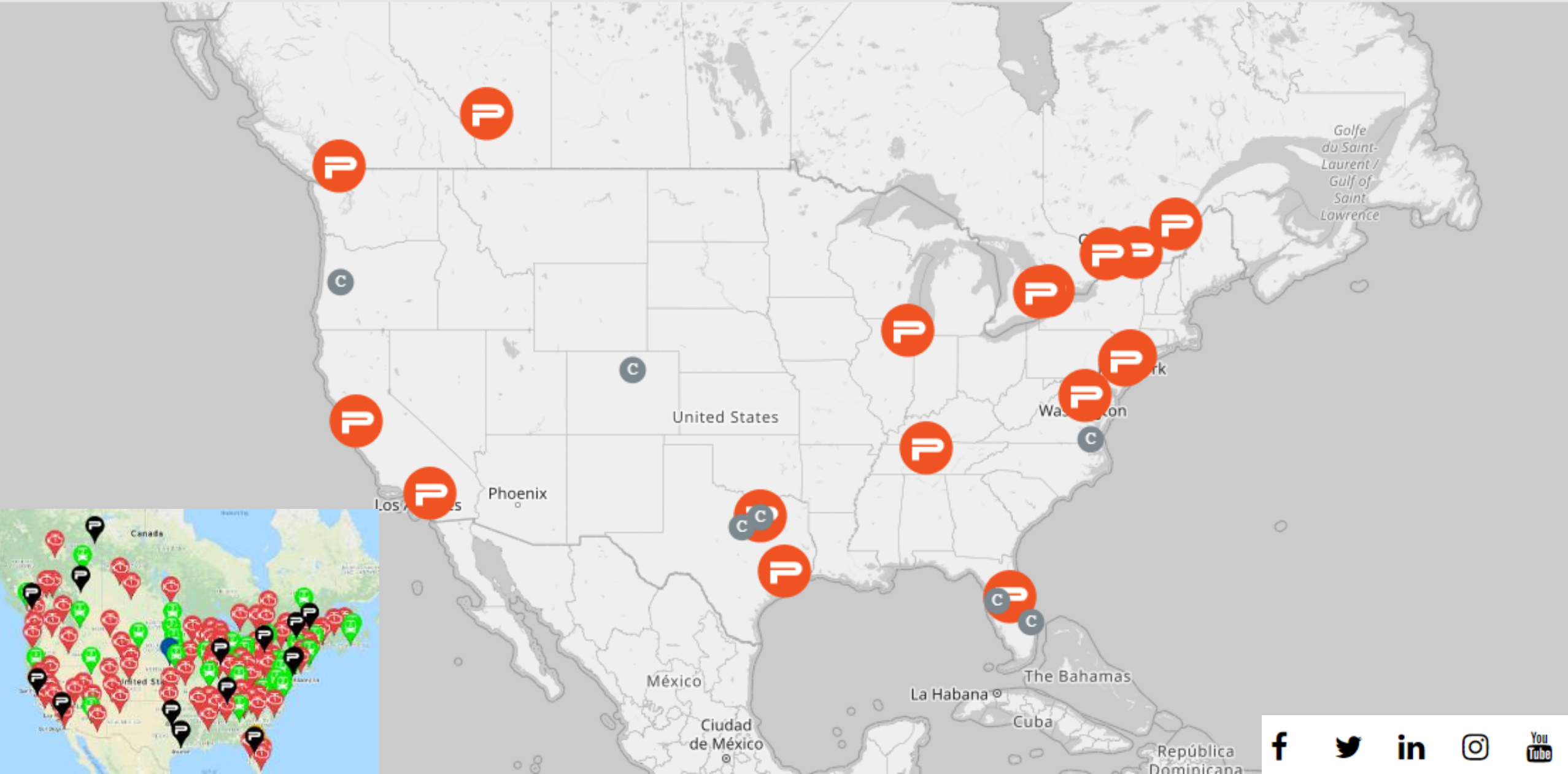

# PREVOST SERVICES OFFERED

- Warranty repairs and campaigns execution.
- Routine Maintenance
- Detailed Mechanical Inspections
- **Volvo Engine Diagnostics and Repairs**
- Electronic Diagnostics
- HVAC Maintenance and Repairs
- Collision Repairs
- Retrofits
- Refurbishing Programs
- Fire Restoration and Refinishing
- Mobile Service
- Red Carpet Treatment
- Remanufactured Engines
- EFD retrofit



# PREVOST PARTS



Prevost's experienced team provides technical support and fast, reliable delivery of quality parts, components and specialized tooling.

- Parts Assist / Online ordering
- Parts for all Prevost models and for most other motorcoaches
- 24/7 emergency parts ordering and shipping
- 24/7 online parts ordering with special discounts
- Same day shipping of stock parts anywhere in the U.S. and Canada for orders received before 2 p.m.
- Online parts catalog



**PREVOST**

**PASS**

**1-800-463-7738**

**PREVOST ON-SITE SERVICE**

**PREVOST**



# 24/7 ROADSIDE ASSISTANCE

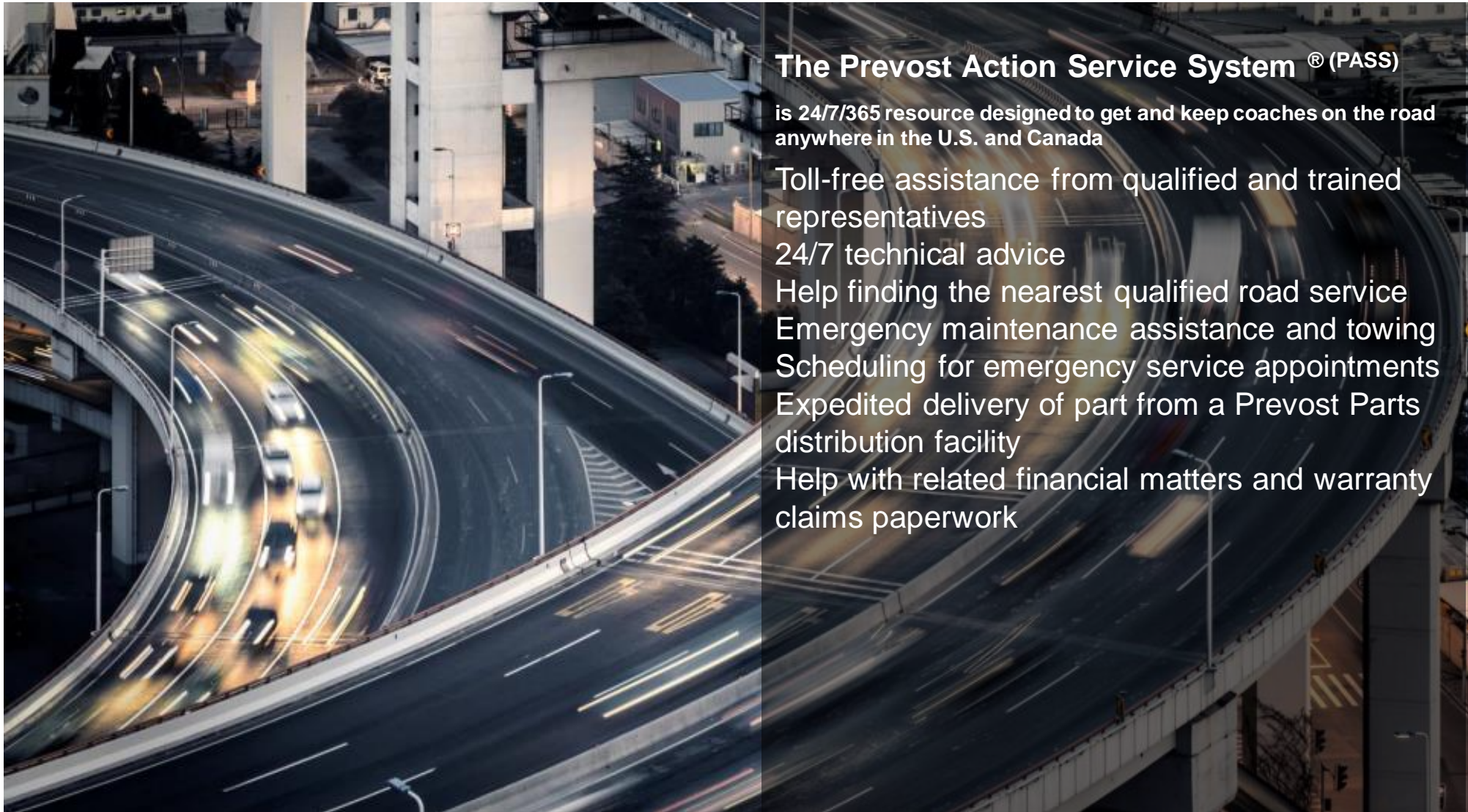

## The Prevost Action Service System<sup>®</sup> (PASS)

is 24/7/365 resource designed to get and keep coaches on the road anywhere in the U.S. and Canada

Toll-free assistance from qualified and trained representatives

24/7 technical advice

Help finding the nearest qualified road service

Emergency maintenance assistance and towing

Scheduling for emergency service appointments

Expedited delivery of part from a Prevost Parts distribution facility

Help with related financial matters and warranty claims paperwork

# Prevost APPS

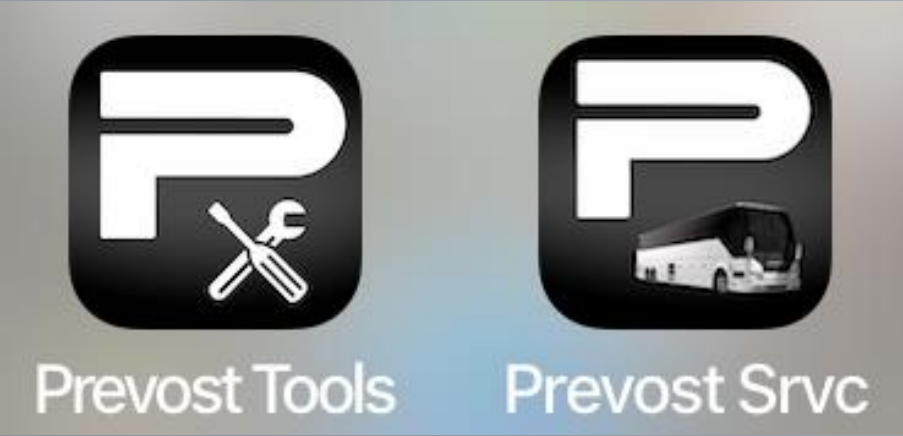

# Prevost Uptime<sup>®</sup>

Preventive Service Agreement

**Uptime Agreements**





# SERVICE AT A GLANCE

PREVH, PREVX Model Year 2011 and newer (not applicable for Commuter Coaches)

D13 Engine EPA 2010 compliant engines and newer	Heavy 6 mpg or less 39 L / 100km or greater		Normal Greater than 6 mpg Less than 39 L / 100km	
	<b>Engine Oil &amp; Filters, Fuel Filters (Replace)</b> Using Volvo Premium VDS-4.5 Motor Oil <i>If idle time is greater than 30%, use Heavy drain level</i>	Miles	45,000	Miles
	Km	70,000	Km	95,000
	Hours	1,300	Hours	1,700
Using Other Volvo Approved VDS-4.5 Motor oils <i>If idle time is greater than 30%, use Heavy drain level</i>	Miles	40,000	Miles	55,000
	Km	65,000	Km	90,000
	Hours	1,200	Hours	1,600
Using Volvo Premium VDS-4 Motor Oil <i>If idle time is greater than 30%, use Heavy drain level</i>	Miles	35,000	Miles	45,000
	Km	60,000	Km	75,000
	Hours	1,000	Hours	1,300
<b>Air Filter</b> Replace the air filter	Time	When indicated by the air restriction indicator. Maximum 24 months		
<b>Coolant</b> <b>Extended Life Coolant.</b> Can only be topped off with premixed 50/50 Extended Life Coolant when coolant level is low	Miles	750,000		
	Km	1,200,000		
	Time	96 months		
<b>Coolant Filters</b> <b>Long Life Filter</b> without additives to be used with Extended Life Coolant	Miles	150,000		
	Km	240,000		
	Time	12 months		
<b>Valve Adjustment</b>	Miles	150,000 / then every 300,000		
	Km	240,000 / then every 500,000		
	Time	12 months / then every 24 months		
<b>Fan &amp; Accessory Drive Belts</b> Inspect at every preventive maintenance	Miles	31,250		
	Km	50,000		
	Time	12 months		
<b>Radiator Fan Gearbox</b> Check oil level, add if necessary	Miles	12,500		
	Km	20,000		
	Time	6 months		
Change oil and seals	Miles	106,000		
	Km	170,000		
<b>Alternators</b> Check alternator drive belt for wear and proper tension	Miles	31,250		
	Km	50,000		
	Time	3 months		

Exhaust Aftertreatment System		Heavy	Normal
<b>Diesel Particulate Filter (DPF)</b> Either clean the ash from the DPF or replace DPF	Miles	400,000	
	Km	650,000	
	Hours	10,000	
<b>Aftertreatment Hydrocarbon Injector (AHI)</b> MY 2011 to 2012, clean AHI nozzle MY 2012 and newer (Parker AHI) replace AHI nozzle	Miles	150,000	
	Km	240,000	
	Hours	4,500	
<b>DEF, Pump &amp; Tank Filler Neck Filter</b> Drain DEF tank, Replace DEF pump main filter, Clean DEF tank neck filter	Miles	150,000	
	Km	240,000	
	Hours	4,500	

Transmission		Heavy	Normal
<b>I-Shift Transmission</b>	Miles	500 000 (Volvo I-Shift transmission Fluids or other Volvo approved oils)	
	Km	800 000 (Volvo I-Shift transmission Fluids or other Volvo approved oils)	
	Time	60 months (Volvo I-Shift transmission Fluids or other Volvo approved oils)	
<b>Allison Transmission B500, B500R (retarder)</b> With TES389 approved fluid and Prognostics mode disabled - change transmission fluid, Main & Lube filters	Miles	25 000 (12 000 B500R)	
	Km	40 000 (20 000 B500R)	
	Time	12 months (6 months B500R)	
With TranSynd or TES295 synthetic fluid only, no mixture and Prognostics mode disabled - change transmission fluid, Main & Lube filters	Miles	Fluid: 300 000 (150 000 B500R)	Filters: 75 000
	Km	Fluid: 480 000 (240 000 B500R)	Filters: 120 000
	Time	Fluid: 48 months	Filters: 36 months
With TranSynd or TES295 synthetic fluid only, no mixture and Prognostics mode enabled - change fluid & filters	Time	60 months or when indicated by <b>TRANSMISSION SERVICE</b> indicator	
With TES389 approved fluid with Prognostics mode enabled - change fluid & filters	Time	24 months or when indicated by <b>TRANSMISSION SERVICE</b> indicator	

Chassis		Heavy	Normal
<b>Power Steering</b> Check power steering fluid condition through visual inspection	Miles	100,000	
	Km	160,000	
	Time	12 months	
Change power steering fluid filter	Time	12 months	
<b>Differential</b> Check oil level, add if necessary	Miles	25,000	
	Km	40,000	
	Time	6 months	
Change oil and clean the breather, magnetic fill and drain plugs	Miles	100 000 / Synthetic Oil 250 000	
	Km	160 000 / Synthetic Oil 400 000	
	Time	12 months / Synthetic Oil 48 months	

These maintenance intervals are general recommendations. Please refer to the appropriate maintenance and lubrication manual for your specific vehicle as the authoritative source for all details of a proper and complete inspection and maintenance plan for your vehicle.

# Prevost Uptime

Preventive Service Agreement



## Seamless process

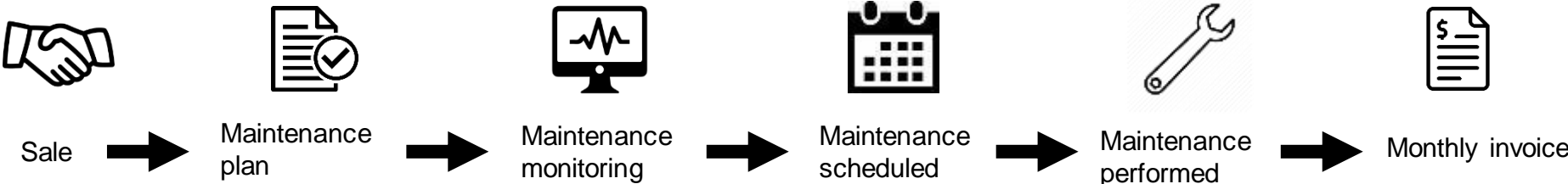

# Prevost UPTIME Maintenance Service Agreements are designed to help you

- Maximize UPTIME, and reduce unplanned stops
- Ease budgeting by fixed costs
- Lock in parts and labor rates
- Allow us to remind you of Preventive maintenance services
- Focus on your life style



# Calculator Example

VALID ONLY for 2021		Labor Rate	Oil Change Interval:	Annual Mi	Years:	Contract miles			Months	Units	Monthly Payment per Unit (USD)	Contract Price (USD)		Payment option per visit (4)
Branch														
FL - Orlando			45,000	10,000	2		20,000		24	1	\$280.18	\$6,724.27		\$1,681.07
Operation	Include?	Interval	Max months	Part no	Part quantity	Part price per unit or liter	Hours	# of Services	Average services per year	Labor cost (USD)	Material cost (USD)	Total cost life (USD)	USD/MI	
<b>Preventive Maintenance Item</b>														
Engine oil and Filters (Volvo D13)	Yes		12											
Engine Air Filter Replacement	Yes		24											
Coolant Filter	Yes		12											
Valve Adjustment	Yes		24											
Gear Box oil replacement	Yes		12											
Replace AHI and DEF filter Tune up	Yes		24											
Replace Transmission Fluid (Allison)	Yes		12											
Replace Transmission Filter (Allison)	Yes		36											
Replace Power Steering Filter	Yes		12											
Replace Transmission Cooler	No		24											
Replace Differential Oil	Yes		12											
Lube Steering and Suspension	Yes		6											
Generator Service (per unit)	No		12		2									
Perform Annual DMI	No		12											
Perform 3 Axle Alignment	No		24											
Annual A/C Inspection	Yes		12											
Annual Wiper Blade Replacement	Yes		12											
Air System Service	Yes		24											
Tensioner Pulley and Belt inspection	Yes		6											
Replace all belts annually	Yes		6											
Brake Lining Inspection (no Wheels Removed)	Yes		12											

**Craig Heaton**

**Prevostcar.com**

**[craig.heaton@volvo.com](mailto:craig.heaton@volvo.com)**

**732 397-5514**



**THE ULTIMATE  
EXPERIENCE**



**PREVOST**